

## Mobile Backhaul evolution

### Market Drivers

The mobile backhaul experiences a major paradigm shift from current PDH and ATM transport to an Ethernet based network. The two main factors driving this transition are the dramatic increase in bandwidth demand and the pressure on mobile operators to reduce costs.

In an effort to raise revenue mobile operators introduce new data-centric services and applications. Supported by 'smart phones', which constitute an increasingly higher percentage of new phones, these new services increase the demand for bandwidth by an order of magnitude and more. The evolution from 3G networks to 4G networks increases the data rate from 1 Mbps for 3G HSPA service to between 10 Mbps and 20 Mbps for 4G (LTE) networks. This growth in bandwidth demand has a high impact on the mobile backhaul network. Whereas 2G networks required 3 Mbps per cell site and 3G networks required 8 Mbps per site, 4G (LTE) cells serving video services demand up to 35 Mbps links.

Older generation networks – 2G and 3G – commonly relied on leased lines for connecting cell sites to base station controllers. The cost of leased line transport constitutes a dominant and increasing part of the Operational Expense (OpEx) incurred by mobile operators. Yankee Group has analyzed this problem and concluded that while lease line costs accounted for 40% of total OpEx for 2G networks they are 60% network related OpEx for 3G network estimated at \$22B per year. The transition from 3G to 4G would result in a factor of 4 increase in OpEx if mobile operators retain the current mobile backhaul architecture, i.e. growing to \$88B per year.

This is a very difficult proposition that would continue to sustain the revenue gap afflicting the financial results of mobile operators. This revenue gap is generated by the decrease in voice services ARPU and the price pressure on data services that many subscribers expect to receive at low or no cost and the concomitant increase in expenses created by the need to provide and support higher bandwidth.

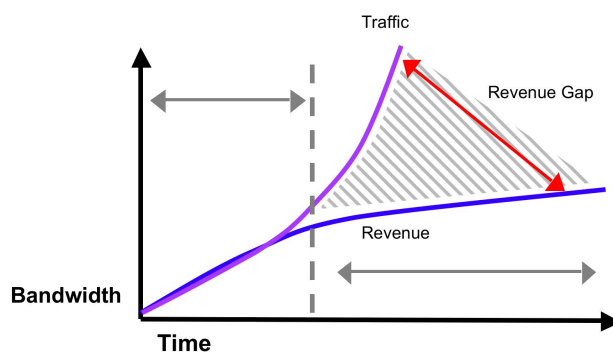

Figure 1. Mobile operators' revenue gap

In order to address the challenge of increased bandwidth demand and contain the rising recurring OpEx, mobile carriers plan to use an all-packet Ethernet-based architecture for the new generation of mobile networks. This move will result in major savings, reducing the mobile backhaul associated OpEx by as much as 75%.

### Network Architecture Evolution

The solution to providing support to LTE bandwidth while containing OpEx costs is changing from a PDH/SDH network to an all-packet network based on Ethernet standards. However, the transition to an all-packet network does not come without a certain price. The original enterprise class Ethernet lacks certain features required for Carrier Class deployment. These are commonly associated with Carrier Grade Ethernet as identified by the Metro Ethernet Forum, and standardized by the ITU-T. The additional features include: per flow operation, synchronization, operational support and management, resilience and scalability. In order to satisfy these requirements, Ethernet based mobile backhaul networks need to comply with all Carrier Grade Ethernet standards promulgated by the ITU-T, IEEE and agreed upon by the Metro Ethernet Forum.

In addition to that, the introduction of an all-packet based mobile backhaul network needs to support a graceful migration from the current PDH/Sonet based network and to continue seamless support of existing 2G and 3G networks that are expected to be with us for five years or more. Support of current 2G and 3G networks takes one of two scenarios: hybrid network or integrated all-packet network.

In a hybrid network, the new Ethernet-based network coexists with the present PDH network. The PDH transmission links continue to serve the existing 2G and 3G networks, while the Ethernet network is used to provide mobile backhaul for newly deployed cell stations. The advantage presented by this deployment model is that it guarantees service continuation for existing 2G/3G networks with no disruption. This however comes at the price of higher OpEx and the need to support two transport networks and management systems: one for TDM/ATM and one for Ethernet. The prevalent view is that this type of network will be transitory and will be replaced in short time by a unified network.

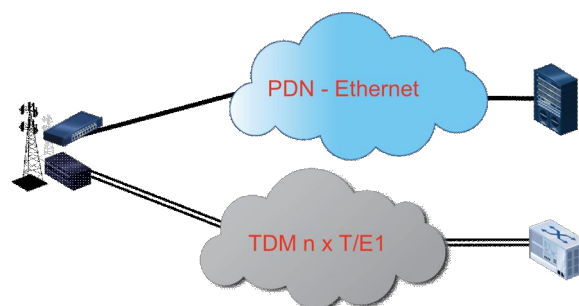

*Figure 2. Hybrid mobile backhaul network*

A unified network is an all-packet, Ethernet based network. Support for present 2G and 3G networks is offered by provision of TDM tunnels using Pseudo Wire technology (PWE3). A unified network benefits Service Providers by reducing the OpEx by as much as 75%, through use of ubiquitous Ethernet technology and a simplified management system.

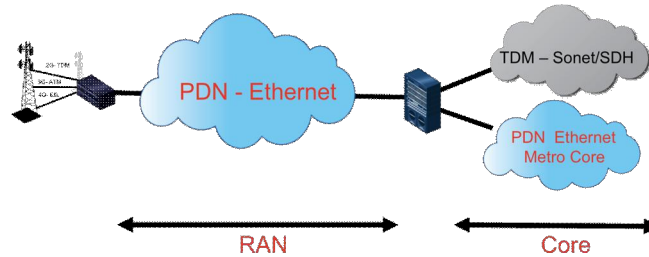

Figure 3. Unified mobile backhaul network

To support the seamless migration from the current TDM based 2G/3G networks to the evolving 4G all-packet network, mobile backhaul equipment needs to support Pseudo Wire interworking functionality, provide the means to synchronize all network elements and provide a true Carrier Grade network management and resiliency.

### Access Network Technologies

Mobile cell stations are situated in different locations – urban, suburban, and rural. The transport network connecting cell station to mobile network controllers (BSC, RNC, 4G NC) uses different transport technologies, depending on availability and selected to achieve optimal cost/performance. In urban and suburban areas, where DSL and PON systems are deployed for residential service, the mobile backhaul network will use these transport technologies. In other areas, mobile backhaul will rely on point-to-point, fiber-based Ethernet. In yet other areas, mobile backhaul will use fixed wireless microwave links.

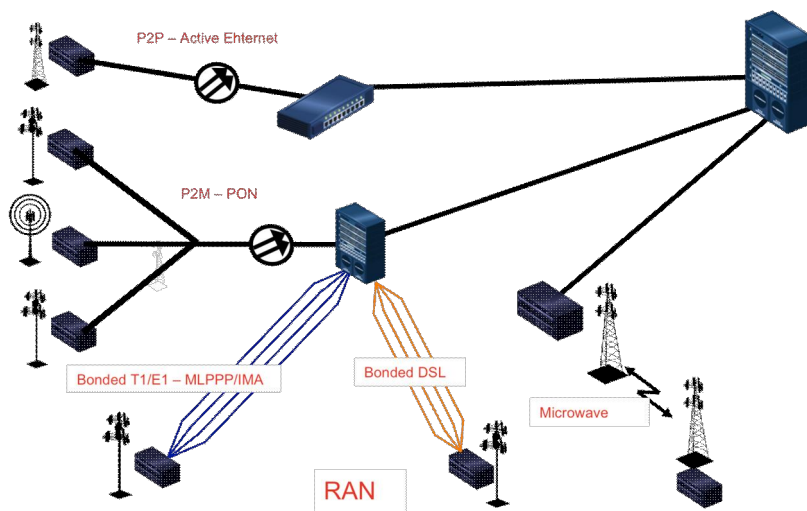

Figure 4. Mobile Backhaul Access Technologies



So, mobile backhaul of the next generation needs to be sufficiently flexible and modular to be efficient irrespective of the transport technology used: DSL, PON (EPON/GPON), fixed microwave wireless, fiber-based Point-to-Point Ethernet.

### **Technical Requirements**

Next generation mobile backhaul transmission systems need to meet a series of requirements to guarantee:

- Performance and user quality of experience
- Management and enforcement of Service Level Agreements (SLA)
- Support of smooth migration from and backward compatibility with legacy 2G and 3G networks
- Support of all available transmission technologies

### **Synchronization**

Mobile networks require highly accurate network synchronization without which the base station and mobile devices may lose contact and inter-cell hand-offs may fail, resulting in dropped calls and degradation of the user quality of experience. To achieve the necessary level of timing accuracy,  $\pm 15$  parts-per-billion (ppb) Fractional Frequency Offset (FFoFF), all network elements (base stations and network controllers) are required to be synchronized with highly accurate primary reference clocks (PRCs).

2G and 3G networks rely on TDM network technologies (for example, SONET/SDH and Plesiochronous Digital Hierarchy [PDH]), which have native capability to carry a timing reference at the physical layer for their synchronization signal. All-packet based networks, on the other hand, rely on Ethernet based transmission technology and standard Ethernet is very lax in its timing requirements. To meet the synchronization requirements of mobile networks, packet based mobile backhaul specifications are augmented and include a requirement to meet timing standards specified by the ITU-T in Recommendation G.8262. Two methods of synchronization are suggested in Rec. G.8262: IEEE 1588v2 and Synchronous Ethernet, each of which has its own advantages and disadvantages.

1588v2 is a Precision Time Protocol (PTP). It is based on specific packets transmitted by a Master Clock node through the network to all Slave nodes. The protocol defines a method of conveying the Master Clock with the frequency accuracy required by mobile and wireline networks. Local adaptive clock recovery algorithms are used to recover the Master Clock's frequency and lock a local system clock to it. The 1588v2 transfers both frequency and time-of-day information through the network. Since it is based on time packets, it can easily convey the Master Clock parameters to synchronous network elements interconnected with sub-networks of asynchronous network elements that do now participate in the protocol. The disadvantage is that since it relies on time packets,



a 1588v2-based network requires strict enforcement of QoS in order to guarantee timely reception of those time packets.

Synchronous Ethernet (SyncE) is based on the embedding of accurate clock at the physical transmission layer. SyncE can be used only in the event that all network elements participating in the mobile backhaul are SyncE enabled. This may complicate the task of achieving interoperability among different vendors, which in this case need all to support SyncE. On the other hand, the frequency accuracy of the synchronization signal is not de. It is relatively easy to use SyncE in a packet based access network, which is limited in the number of hops and ultimately a L2 network.

The decision on which of the two methods to use for network synchronization ultimately depends on the topology of the network and the service provider. Mobile backhaul system vendors will be required to support both methods.

### **Management – (Operations, Administration, Maintenance- OAM)**

The transition from a TDM-based mobile backhaul to an all-packet Ethernet-based one needs to guarantee that service provider management requirements continue to be fulfilled. Ethernet was originally designed as a local area network and its management hooks are minimal. As Ethernet replaces legacy TDM services in QoS sensitive, high-capacity applications such as mobile backhaul, ensuring service quality and Service Level Agreement (SLA) compliance requires a well-managed, operationally efficient network. To achieve this goal, the IEEE and ITU-T have defined a series of Ethernet connectivity and service layer Operations, Administration and Maintenance (OAM) standards designed to simplify the management of Carrier Ethernet services with end-to-end service visibility, fault isolation, reporting and continuous performance monitoring.

Mobile backhaul system vendors are required to support functionality needed to comply with the applicable standards: IEEE 802.1ag and ITU-T Recommendation Y.1731. Compliance with these standard create the framework that enables service providers to manage Ethernet services regardless of the network path, topology, operators or network layer that carries the traffic between service endpoints.

Mobile backhaul systems are also required to support corrective action in case of failure, i.e., support of redundancy and protection protocols devised to maintain service in the presence of equipment and facility failures. TDM and ATM based equipment is designed to provide this degree of protection, which is included in TDM and ATM standards. Next generation Ethernet-based mobile backhaul systems need to provide a similar level of protection, based on IEEE 802.1ag and ITU-T Recommendation Y.1731 and the ITU-T G.8031 standards.

In order to maintain a accurate view of the network and to complete recovery actions within the 50 msec period mandated by operators, mobile backhaul network elements are required to generate, analyze and respond to continuity messages within a very short period of time – 3 msec. The computational burden created by these management tasks are best served by hardware message generators and analyzers to prevent the overloading of general purpose host processors and avert the need for high performance processors on each line card.



### **Pseudowire Edge to Edge (PWE3)**

Current mobile backhaul networks supporting 2<sup>nd</sup> and 3<sup>rd</sup> generation mobile base station equipment were designed using PDH or Sonet/SDH based networks comprised of T1/E1 and DS3 leased line circuits delivered via wire-line or microwave infrastructure and carrying TDM or ATM payloads. While Ethernet was selected as the all-packet technology for the next generation of mobile backhaul, the fact remains that the transition from 3G to 4G networks will take a few years and mobile operators will continue to have to transport TDM (for 2G) and ATM (for 3G) for this period of time. This means that Ethernet must be able to provide seamless transport for the existing TDM services being used to connect remote base stations to mobile aggregation and radio controller equipment located in the Central Office.

In order to support coexisting TDM (for 2G networks), ATM or PPP (for 3G networks) and Ethernet (for HSAP and 4G networks), mobile backhaul networks using Ethernet networks are required to transport TDM and ATM and PPP payloads. To support TDM or transport agnostic of ATM and PPP, next generation mobile backhaul Cell Gateways and Radio Access Network Controllers will implement pseudo-wire Interworking Functions providing encapsulation and termination according to SAToP (Structure Agnostic Transport over Packet), or CESoPSN (Circuit Emulation Service over Packet Switched Networks) when there is a need to look on the E1/T1 frame and transmit a portion of the frame. For better optimization of ATM and PPP data traffic Radio Access Network Controllers will implement and support dedicated handle for ATM and PPP according to ATMoPSN (ATM over Packet Switched Network), IMA, PPPoPSN and MLPPP standards. Mobile backhaul all-packet networks are required to deliver TDM services with the same quality as traditional PDH and Sonet/SDH networks and comply with jitter and wander specifications outlined in ITU-T Recommendations G.823, G.824, G.825. To that end, all-packet mobile backhaul networks need to implement strict traffic management policies to guarantee the jitter, wander and delays that TDM services need to meet. This requires the implementation of sophisticated dynamic admission control, policing and multi-level hierarchical scheduling by all nodes in the network.

### **Access Technologies**

Although the emerging mobile backhaul network transitions to an all-packet, Ethernet network using a single Layer 2 technology, it will continue to use different technologies at the Physical, Layer 1 level. The different Layer 1 technologies are:

- Copper cables using traditional E1/T1 services
- Copper cables using DSL services
- Point-to-Multipoint Passive Optical Networks (PON)
- Point-to-Point active Ethernet
- Point-to-Point Fixed Microwave wireless

Operators will use several or all of these techniques in order to meet in-time installation and reduce operational expenses. The decision is made on a case by case basis and



depends on availability and cost. As result, mobile backhaul systems need to be flexible and able to support all of the above technologies while maintaining a unified management system and insulating the operator from operational impact generated by the use of different technologies. A few features particular to the different technologies are reviewed below.

### **Mobile backhaul over PDH and SONET/SDH**

The number of cell sites connected over T1/E1 leased lines is still significant, in particular in the US, but as data services take front stage, operators need to increase the available bandwidth to these sites. The simplest and fastest way to do so, albeit incurring higher expenses, is to use bonded T1/E1 access using MLPPP and GFP-VCAT for Ethernet encapsulation and Inverse Multiplexing ATM (IMA) for ATM payloads used for 3G.

### **Mobile backhaul over DSL**

The use of DSL lines is a very attractive and cost effective solution, in particular in urban and suburban areas, where DSL has been widely deployed.

There are three DSL technologies that can be used to that end: G.SHDSL, ADSL2+ and VDSL. The difference among the three technologies is in the supported bandwidth and reach. G.SHDSL serves the longest reach, but delivers only 2.5 Mbps per wire pair. VDSL2, on the other hand, can deliver up to 50 Mbps over a distance of 1 Km. In order to support data rates required by 4G (LTE) networks, DSL based equipment needs to deliver a high bandwidth of 500 Mbps and higher per cell base. To that end, mobile backhaul equipment needs to implement EFM bonding of a number of pairs using per Recommendation ITU-T G.998.2.

### **Mobile backhaul over PON**

Point-to-Multipoint (P2MP) fiber technologies – EPON and GPON - are deployed today by many wireline Service Providers and are starting to take over DSL as the preferred technology for broadband access delivery. As PON systems become increasingly present in metro and sub-urban areas, the use of PON as the mobile backhaul transport technology of choice will increase. There are several reasons for that. PON technology, contrary to DSL, does not require a trade-off between distance and throughput and can deliver 100 Mbps to a distance of 20 km with no difficulty. Since PON is a technology addressing the residential market, high volumes and service price pressure guarantee a low cost of service, i.e. OpEx.

While GPON systems use precise, PRC derived 8 kHz timing, EPON system can support the required timing/synchronization signal using Ethernet synchronization protocols, SynchE or 1588v2, as discussed above.



### **Mobile backhaul over optical Ethernet**

This method is the most straightforward of all, being based on standard Ethernet interfaces. The down side of using this method is the need for a fiber rich network that may be costly to deploy.

### **Mobile backhaul over Fixed Microwave**

Widely used in Europe and other parts of the world, microwave point-to-point (P2P) radio provides a number of benefits that make it ideally suited for next-generation backhaul applications. Microwave cellular backhaul has several inherent advantages: low acquisition cost (CapEx) as it does not require costly civil engineering work for infrastructure, low operational cost (OpEx) as it doesn't require leasing transmission capacity from fixed wireline operators, short deployment time and long reach.

Use of Microwave P2P for mobile backhaul does not come without a price, however. First of all, in order to deploy a mobile backhaul based on microwave links, the operator must obtain the necessary spectrum. This can be difficult in certain countries, as the situation in the US shows. Second, microwave links' capacity is susceptible to weather conditions and available bandwidth can fluctuate widely with time of day and rain. To address this problem, microwave based systems must be able to implement a number of traffic management profiles, be able to interact with the radio front end to receive indication of the link quality and to switch between several traffic management profiles based on these indications.

### **Mobile backhaul over Free Space Optics**

Free Space Optics (FSO) is a transport technology similar to Fixed Microwave. It relies on the transmission of optical systems over the air using high power lasers. FSO presents the same benefits as microwave, i.e. low acquisition costs due to low infrastructure investment. They also suffer from similar problems as fixed microwave links, although FSO links are affected by fog and not by rain, like microwave. Several vendors have created dual mode systems with FSO and microwave acting as a back for one another.

### **Mobile Backhaul Network Elements**

The industry consensus is that the emerging Mobile Backhaul network should be based on a Layer2 packet network. This network needs to support aspects related to the efficient transport of 4G mobile services – data and voice – and at the same time to guarantee a seamless migration from the current 2G and 3G networks. To that end, Network Elements participating in a Mobile Backhaul network need to support:

- Hierarchical Traffic Management
- Carrier Grade Ethernet OAM
- Synchronization – SyncE and 1588v2
- Pseudowire (PWE3) for both TDM, ATM, and PPP

In order to support Mobile Backhaul services universally, Mobile Backhaul oriented Network Elements need to support a variety of transport technologies:

- Optical transport
- Fixed wireless
- DSL with Ethernet bonding
- T1/E1 with bonding

Any mobile backhaul network requires two types of network elements: a Cell Tower Gateway and a Network Edge Aggregator.

### Cell Tower Gateway (CTG)

The Cell Tower Gateway (CTG) is located at the cell tower and connects a number of base stations to the all-packet, Ethernet mobile backhaul network. Its function is to connect base stations of different generations – 2G, 3G, 4G to the all-packet RAN. To that end, the CTG includes pseudo-wire (PWE3) Interworking Functions for interconnecting PDH and ATM payloads serving 2G and 3G base stations. The CTG is required to serve as termination point for CGE OAM packets to support network management functionality. It also implements a local Stratum 3 clock derived from SyncE or 1588v2 slave function.

The CTG is required to support all technologies available in the RAN – PDH, DSL, PON, fixed microwave links and P2P optical Ethernet. This capability can be achieved by a modular design, where the CTG Layer 2 functionality is independent of the RAN PHY technology and only PHY related sub-assembly is network related.

To accommodate future growth, a CTG should have a data throughput capability of 10 Gbps.

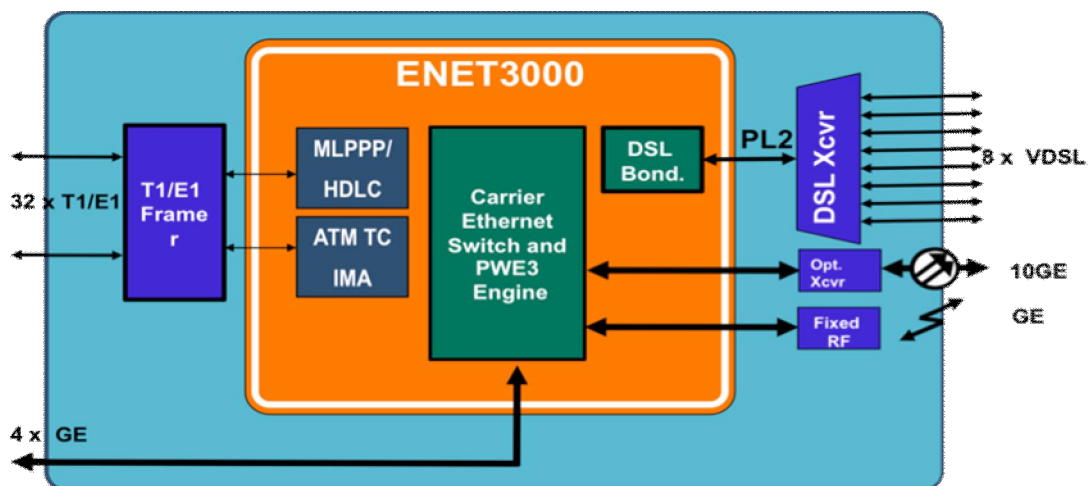

*Fig. 5 Cell Tower Gateway Pizza Box Block Diagram*

For a modular cell tower gateway design the ENET solution can be spitted to a chipset solution where a pure Carrier Ethernet solution together with Jitter buffer , reordering engine and synchronization is located on a main board and a companion FPGA that holds Ingress and Egress TDM fifos is located on a TDM Module through Giga Ethernet interface or **G.999.1** Channelized Gigabit Interface

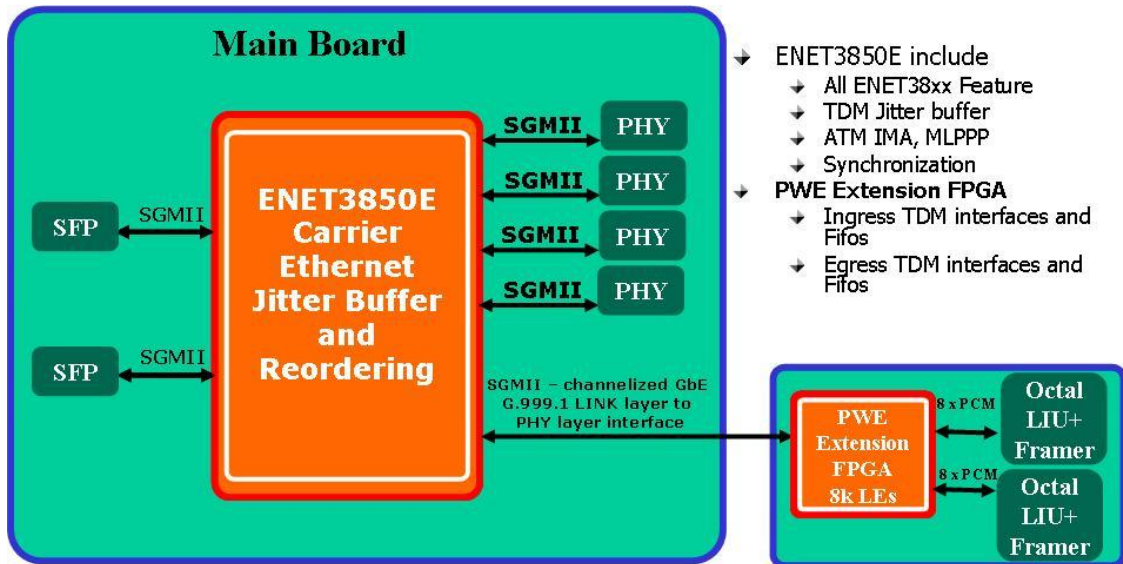

*Fig. 6 Cell Tower Gateway Modular System Block Diagram*

**Network Edge Aggregator (NEA)**

The Network Edge Aggregator is the second network element in the RAN. Its function is to connect and multiplex services from a number of base stations and to groom signals from different mobile generations and direct them to the appropriate radio controller.

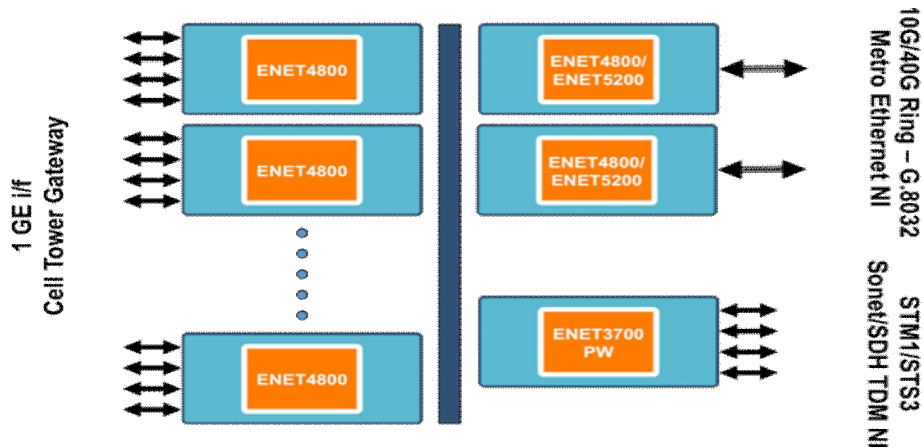

*Fig 7. Network Edge Aggregator Block Diagram*

The NEA grooms PDH and ATM payloads serving 2G and 3G networks, aggregates them in a higher order signal, e.g. DS3, OC3/STM1, and connects with the appropriate network controllers.

It also generates synchronization clock for the subtended CTGs, based on PRC traceable clock input from BITS, GPS or received from a Master clock using 1588v2, SyncE or from a PDH/Sonet-SDH signal.

NEA throughput is dependent on the number of CTGs served and can scale from 40Gbps to 200 Gbps. It will use different RAN technologies to connect to the subtended CTGs.

NEA can be implemented in a Multi Service Access Platform, that embodies IP-DSLAM and GPON/EPON OLT functionality in the same chassis and delivers residential broadband wireline services and mobile backhaul simultaneously.

**The Ethernity Mobile Backhaul solution– ENET3000 and ENET4000 Access Processors**

Ethernity Networks Access Processors provide the preferred solution for designing efficient and cost effective Cell Tower Gateways and Network Edge Aggregators. The ENET3000PW family is optimized for CTGs and NEA Sonet/SDH Line cards, and the ENET4000 provides an optimal solution for high port count Network Edge Aggregator line cards and Network Interface/Switching Cards.

The ENET3000 and ENET4000 designs are based on an Ethernity proprietary architecture and are implemented on state-of-the-art FPGAs. The fragment based



architecture requires a single memory access per packet and results in an efficient use of FPGA resources, resulting in a cost effective solution.

The ENET3000 family scales from 2 Gbps up to 12 Gbps throughput. The devices are optimized for mobile backhaul CGT and NEA applications and incorporate:

- Versatile classification rules
- Per-flow and per-port policing and metering
- 4-level hierarchical scheduling
- EFM bonding
- Support for SyncE and 1588v2
- CGE OAM hardware processors
- PWE3 for SAToP/CESoPSN, ATM and PPP traffic.

Entry level ENET3200PW and 3500PW with a throughput of 2 Gbps and 4.5 Gbps provide a cost effective solution for Cellular Tower Gateways while the ENET3700PW delivers an optimal solution for NEA Sonet/SDH service gateway service cards for interfacing with the legacy Sonet/SDH transport network. The ENET4800, with a 40 Gbps throughput provides the optimal solution for NEA Ethernet line cards, connecting the NEA to the Metro Ethernet Network.

The ENET4800 (40Gbps throughput) and ENET5200 (80Gbps throughput) provide a perfect solution for NEA Network Interface/Switch Cards.

The ENET3000 and ENET4000 families are based on hardware configurable devices. All packet processing and inter-working functions are implemented in hardware and deliver deterministic performance at all speeds. The ENET Access Processors are configurable and not programmable and as such do not require the major software effort required by network processors. The two families use identical APIs to reduce the software development required by system designers.

In conclusion, using the ENET3000 and ENET4000 families, Telecommunication Equipment Manufacturers (TEMs) can design a cost effective solution for the next generation of mobile backhaul networks in record time. Implemented on a FPGA, the Ethernity solution can evolve with the emergence of new protocols and can also integrate proprietary functions to create an even more cost effective solution.